

DETTAGLIO H
SPESSORE PUNTI DI ATTACCO REV3
SCALA 1 : 1

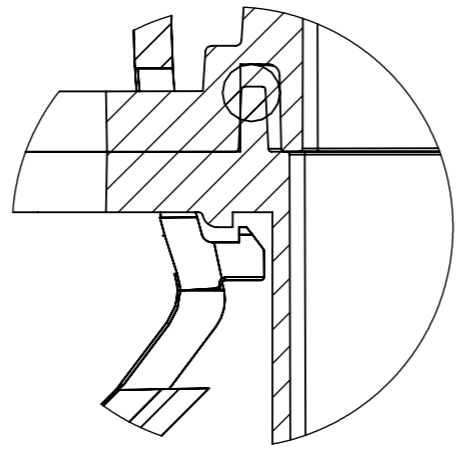

DETAIL D
SCALA 2 : 1

Notes		GENERAL TOLERANCES from UNI EN 2768-1													
General geometric tolerances		L UNI EN 2768-2 Class		Limit of deviation											
Angular dimensions without indication of tolerance		± 2°													
Dimension without indication of tolerance		c UNI EN 2768-1 Class													
Surface without indication of tolerance		Not quoted chamfer													
Not quoted fillet		Not quoted fillet													
Unless otherwise specified, remove the sharp edges		Unless otherwise specified, remove the sharp edges													
Range of tolerance		from 0.5 up to 3	from 3 up to 6	from 6 up to 30	from 30 up to 120	from 120 up to 400	from 400 up to 1000	from 1000 up to 2000	from 2000 up to 4000						
subtle	±0.05	±0.05	±0.1	±0.15	±0.2	±0.3	±0.5	±0.8	±1.2	±2	±3	±4			
medium	±0.1	±0.1	±0.2	±0.3	±0.5	±0.8	±1.2	±2	±3	±4					
approximate	±0.2	±0.3	±0.5	±0.8	±1.2	±2	±3	±4	±6	±8					
very approximate	-	±0.5	±1	±1.5	±2.5	±4	±6	±8							

REV.	DATE	DESCRIPTION OF REVISION	DRAWN BY	CHECKED BY	APPROVED BY
3	21/05/21	RIDOTTO SPESSORE PUNTI DI ATTACCO A 3MM	G. ATLANTE	G. ATLANTE	D.LORUSSO
2	14/02/19	SOSTITUITO TAPPO 200200062 - CON TAPPO 200200164	A.MUSCI	D.BARATTINI	D.LORUSSO
1	12/09/2017	SOSTITUITA MATERIA PRIMA 100300001 CON 100300000	D.BARATTINI	D.BARATTINI	D.LORUSSO

N. OF PCS	WEIGHT [KG]	MATERIAL	DIMENSION	COLOUR [RAL]	TREATMENT	COMMERCIAL		NO
6	0.650	PP	318X67X367	BLACK	-	SCALE	SHEET DIMENSION	
DESCRIPTION						DATE	SHEET:	
PORTADOCUMENTI "RIGHT" *318x67x367						22/04/2017	1 DI 1	
PRODUCT CODE						DRAWN BY	SHEET:	
603010100						Eng. D.Barattini	1 DI 1	
						CHECKED BY	LOKHEN	
						Eng. D.Barattini		
						APPROVED BY		
						D.Lorusso		

POS.	COD.	MATERIALE	Descrizione	Q.TA'
1	503010103	PP	COPERCHIO PORTADOCUMENTI CON MANIGLIA, SPINA 1 ,2 COMPLETO DI GUARNIZIONE	1
2	200200164	PP	OTTURATORE KAP 610 B 5.0 X 8.0 NERO	4

THIS DRAWING IS THE PROPERTY OF LOKHEN SRL. IT SHOULD NOT BE REPRODUCED, PUBLISHED OR DISCLOSED WITHOUT WRITTEN AUTHORIZATION.
THIS DRAWING WAS CREATED WITH CAD ANY CHANGES OR MANUAL CORRECTION ARE PROHIBITED.